



NOT D.B.

Keyboard Encoder Circuits

For additional application information, see AN-128 and AN-139 at the end of this section.

not on 2/B

MM5740 90-key keyboard encoder

general description

The MM5740 MOS/LSI keyboard encoder is a complete keyboard interface system capable of encoding 90 single pole single throw switch closures into a usable 9-bit code. It is organized as a bit paired system and is capable of N key or two key rollover. The MM5740 is fabricated with silicon gate technology and provides for direct TTL/DTL compatibility on Data and Strobe outputs without the use of any special interface components.

- Only one TTL level clock required
- N key/two key rollover (mask programmable)
- 90 key-quad mode capability
- One character data storage
- Repeat function (selectable)
- Shift lock with indicator capability
- Key bounce masking by single external capacitor
- Level or pulse data strobe output
- Data strobe pulse width control

features

- TRI-STATE® data outputs directly compatible with TTL/DTL or MOS logic
- Function inputs directly compatible with TTL/DTL logic

block and connection diagrams

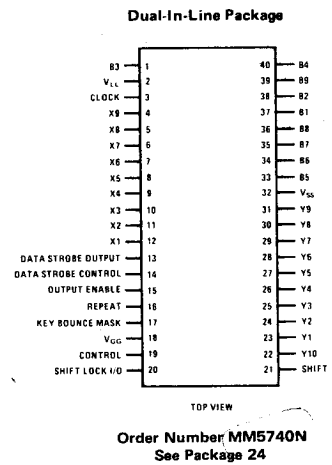
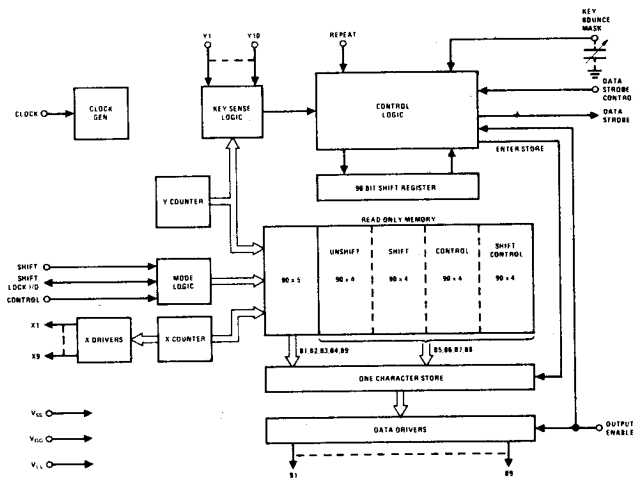

TRI-STATE is a registered trademark of National Semiconductor Corp.

absolute maximum ratings

Data and Clock Input Voltages and Supply

Voltages with Respect to V_{SS}

+0.3V to -20V

Power Dissipation

600 mW at $T_A = +25^\circ\text{C}$

Operating Temperature

25°C to +70°C ambient

Storage Temperature

65°C to +160°C

Lead Temperature (Soldering, 10 seconds)

300°C

electrical characteristics (Note 1,5)

PARAMETER	CONDITIONS	MIN	TYP	MAX	UNITS
Clock Repetition Rate		10		200	kHz
Clock Pulse Width	Rep. Rate = 200 kHz	2.4		2.6	μs
	Rep. Rate = 10 kHz	20		80	μs
Clock Amplitude	Logic Level "0"			3.25	V
	Logic Level "1"	+0.4			V
Clock Transition Times	Risetime			100	ns
	Falltime			100	ns
	Rep. Rate = 200 kHz				
Clock Input Capacitance			5.0		pF
Data Input Levels, Y1 thru Y10	Logic Level "0"			$V_{SS} - 1.5$	V
	Logic Level "1"	-4.5			V
	Logic Level "0"			3.25	V
	Logic Level "1"	+0.4			V
Data Strobe Control	Logic Level "0"			+3.5	V
	Logic Level "1"	+0.4			V
Data Output Levels, X1 thru X9	Logic Level "0"			$V_{SS} - 0.75$	V
	Logic Level "1"	4.5			V
B1 thru B9 and Data Strobe	Logic Level "0"			$V_{SS} - 1.0$	V
	Logic Level "1"	+0.4			V
Shift Lock Voltage Open	Before Closure		$V_{GG} - 2.0$		V
Shift Lock Voltage Closed	Switch Closed		V_{SS}		V
Shift Lock Voltage Locked	After Release, (I = 1.0 mA) (Figure 2)		$V_{SS} - 5.0$	$V_{SS} - 8.0$	V
Transition Times	Data Strobe (T_{DS1})			2.5	μs
	Data Strobe (T_{DS0})			1.0	μs
Data Output Levels (T_{DO1}) (T_{DO0})	$C_L = 100 \text{ pF}, I = 1.6 \text{ mA}$			2.5	μs
	$C_L = 100 \text{ pF}, I = 100 \mu\text{A}$			1.0	μs
Output Enable Setup Time (T_{OES})		2.5			μs
Output Enable Release Time (T_{OER})		2.5			μs
Repeat Input Pulse Width (T_{RPW})	(Note 3)				
	$f_{\text{CLOCK}} = 10 \text{ kHz}$	10			ms
	$f_{\text{CLOCK}} = 200 \text{ kHz}$	0.5			ms
Power Supply Current	I_{GG}, I_{SS}		20	35	mA

Note 1: These specifications apply for $V_{SS} = +5.0 \text{ VDC} \pm 5\%$, $V_{GG} = -12.0 \text{ VDC} \pm 5\%$, $V_{LL} = \text{GND}$ and $T_A = 0^\circ\text{C}$ to $+70^\circ\text{C}$.

Note 2: When outputs B1 thru B9 and Data Strobe are driving TTL/DTL $V_{SS} - V_{LL} \leq 5.25\text{V}$. When driving MOS, $V_{SS} - V_{LL} \leq 10.0\text{V}$.

Note 3: $T_{rpw} \text{ min.} = 100 \times \frac{1}{f_{\text{CLOCK}}}$

Note 4: If shift and control inputs are derived from a single pole, single throw switch closure to V_{SS} , a 100 OHM resistor returned to V_{LL} (GND) is required on these inputs.

Note 5: The following inputs have internal pull-up resistors to V_{SS} : clock, output enable, repeat, shift, control.

description of pin functions

NAME	PIN NO.	FUNCTION
X1-X9	4-12	These pins are chip outputs which are used to drive the key switch matrix. When activated (at the appropriate scan time) they are driven high.
Y1-Y10	22-31	Pins 22-31 are the Y sense inputs which are connected to the X drive lines via the key switch matrix. They are internally precharged to a low state and are pulled high upon switch closure.
B1-B9	1, 33-40	These are the data outputs which represent the code for each keyswitch. They are TRI-STATE outputs with direct TTL compatibility. When the output enable input (Pin 15) is high, these outputs are in the third state.
Data Strobe Output	13	The function of this pin is to indicate that valid data has been entered by the keyboard and is ready for acceptance. An active data strobe is indicated by a high level. The data strobe may be operated in the pulse or level mode as indicated by the timing diagram.
Data Strobe Control	14	The basic purpose of this input is to provide data strobe output pulse width control. When connected to the data strobe output (Pin 13), the data strobe will exhibit a one bit wide pulse width. The pulse width may be varied by interposing an RC network between the data strobe output and the strobe control input. For level mode of operation the data strobe control input may be tied to V_{SS} or to the data strobe output.
Output Enable	15	This input serves to TRI-STATE the data output (B1-B9) lines. In addition, it controls the return of the data strobe to the idle condition (low state) which is needed in the level strobe mode of operation.
Repeat	16	The repeat input is designed to accept a repeat signal via the repeat key. One data strobe will be issued for each positive interval of the repeat signal. Thus, if a 10 Hz signal is applied to the repeat input via the repeat switch, a 10 character per second data strobe will be issued when a data key and the repeat key are held depressed.
Key-Bounce Mask	17	This pin is intended as a timing node to mask switch key-bounce. The mask time interval is generated by connecting a capacitor to this pin.
Shift	21	When this input is brought to a logic "0" (V_{SS}) level, the encoder will assume the shifted character mode.
Control	19	A logic "0" places the encoder in the control character mode.
Shift Lock I/O	20	This pin is intended to serve as an input when the shift lock key is depressed. It places the encoder in the shift mode. Upon release of the key, the shift mode will be maintained and this pin will serve as an output to drive an indicator. This function is reset by depressing the shift key.
Clock	3	A TTL compatible clock signal is applied to this pin. A bit time is defined as the time from one negative going transition to the succeeding negative going transition of the clock.
V_{SS}	32	+5.0V supply
V_{LL}	2	Ground
V_{GG}	18	-12V supply

timing diagram

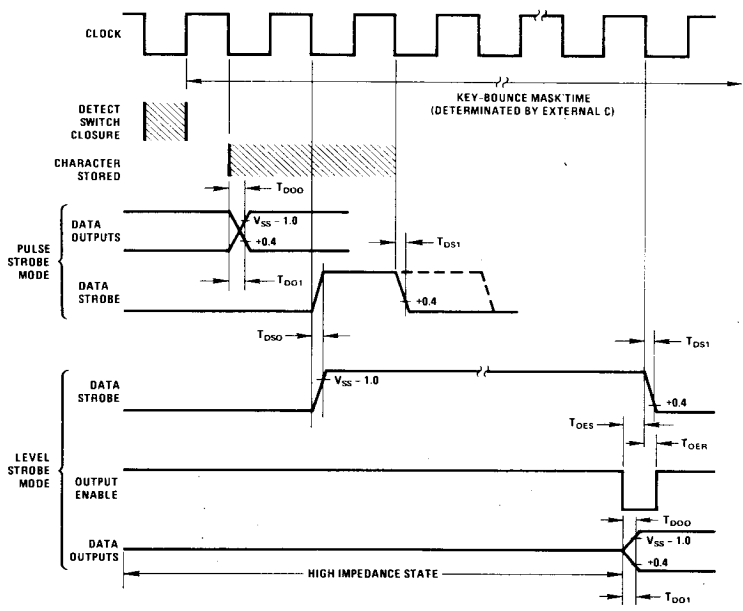

applications information

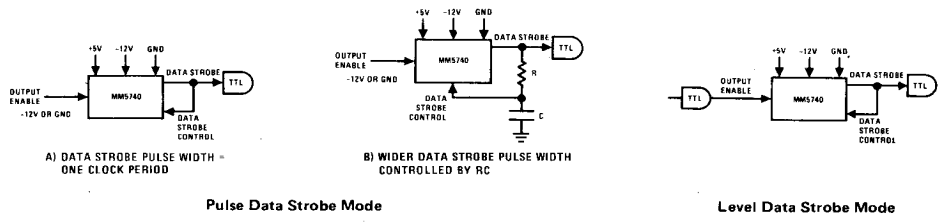

key bounce capacitor values

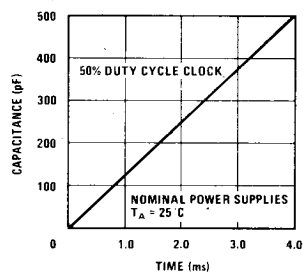

FIGURE 1. Key-Bounce Mask Time

application

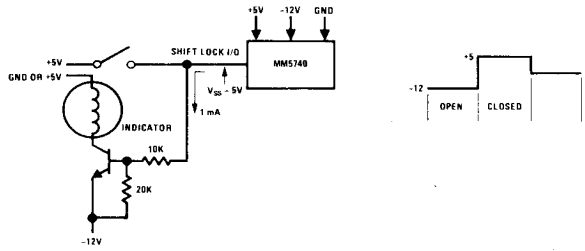
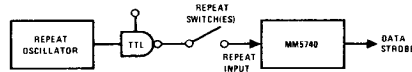
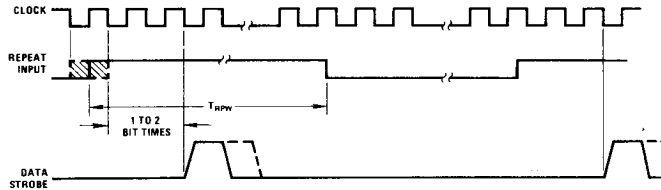

FIGURE 2. Shift Logic I/O Interface

repeat switch function



Repeat Switch Connections



Note: Both Repeat Switch and a Data Key must be depressed to enable repeat function. For N-Key Rollover, the data outputs will represent the current valid data key (N Key Roll during Repeat).

Repeat Function

typical applications

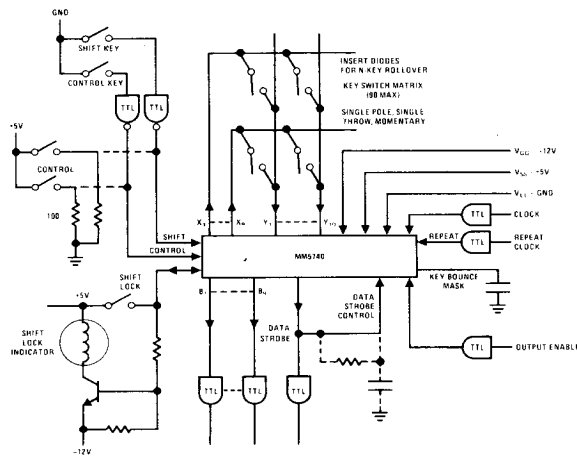

CODE ASSIGNMENT CHART

Customer: _____
Date: _____

MATRIX ADDRESS		COMMON					UNSHIFT				SHIFT				CONTROL				SHIFT CONTROL				CHARACTER			
X	Y	B ₁	B ₂	B ₃	B ₄	B ₉	B ₅	B ₆	B ₇	B ₈	B ₅	B ₆	B ₇	B ₈	B ₅	B ₆	B ₇	B ₈	B ₅	B ₆	B ₇	B ₈	US	S	C	SC
(Note 3)	1																									
	2																									
	3																									
	4																									
	5																									
	6																									
	7																									
	8																									
	9																									
	10																									
	1																									
	2																									
	3																									
	4																									
	5																									
	6																									
	7																									
	8																									
	9																									
	10																									
	1																									
	2																									
	3																									
	4																									
	5																									
	6																									
	7																									
	8																									
	9																									
	10																									

N-Key Rollover
 2 Key Rollover
Page of 3 (Note 1)
Note: Use B8 if parity bit is desired

Note 1: 3 code assignment charts are required for each keyboard encoder pattern. Fill in a "1" or "0" in each output box (B₁ thru B₉). Indicate page number.
Note 2: The matrix is 9 "X" locations by 10 "Y" locations.
Note 3: Write in 10 one's, 10 two's, etc. in successive X address locations up to 9. This will fill 3 charts. The first page will have address matrix location 1,1; 1,2: 1,3... 1,10; 2,1; 2,2... 2,10; 3,1, etc. up to 3,10. Page 2 has 4,1 to 6,10. Page 3 has 7,1 to 9,10.
Note 4: A contact closure at the address matrix location will cause the appropriate bit pattern to appear at the output in negative true logic. V_{OH} = "0"; V_{OL} = "1."
Note 5: See application note AN-80 for coding example.

MM5740AAE, MM5740AAF CODE ASSIGNMENT CHARTS

MATRIX ADDRESS		COMMON					UNSHIFT				SHIFT				CONTROL				SHIFT CONTROL				CHARACTER			
X	Y	B1	B2	B3	B4	B5	B6	B7	B8	B5	B6	B7	B8	B5	B6	B7	B8	B5	B6	B7	B8	US	S	C	SC	
1	1	0	0	0	0	1	1	0	0	1	1	0	1	1	1	0	1	1	1	0	1	1	0	1	0	
1	2	0	0	1	0	0	1	1	0	1	1	0	1	1	1	0	1	1	1	0	1	1	0	1	0	
1	3	1	0	1	0	0	1	1	0	0	1	1	0	0	1	1	0	0	1	1	0	0	1	1	0	
1	4	1	0	0	0	0	1	1	0	0	1	1	0	1	1	1	0	1	1	1	0	1	1	1	0	
1	5	0	1	0	0	0	1	1	0	1	1	0	1	1	1	0	1	1	1	0	1	2	2	2	2	
1	6	1	1	0	0	0	1	1	0	0	1	1	0	0	1	1	0	0	1	1	0	0	3	3	3	
1	7	0	0	0	0	1	1	1	0	0	1	1	0	0	1	1	0	0	1	1	0	0	0	0	0	
1	8	0	1	1	0	0	1	1	0	0	1	1	0	0	1	1	0	0	1	1	0	0	6	6	6	
1	9	1	0	0	1	0	1	1	0	0	1	1	0	0	1	1	0	0	1	1	0	0	9	9	9	
1	10	1	1	1	0	0	1	1	0	1	1	0	1	1	1	0	1	1	1	0	1	7	7	7	7	
2	1	0	0	1	0	0	0	0	0	0	0	0	0	0	0	0	0	0	0	0	0	FF	FF	FF	FF	
2	2	1	0	1	1	0	0	0	1	0	0	0	1	0	0	0	1	0	0	0	1	CR	CR	CR	CR	
2	3	0	0	1	1	0	0	1	0	0	0	1	1	0	0	1	1	0	0	1	1	FS	FS	FS	FS	
2	4	1	0	1	1	0	0	1	0	0	0	1	1	0	0	1	1	0	0	0	1	GS	GS	GS	GS	
2	5	1	1	0	1	0	0	0	0	0	1	0	0	0	1	0	0	0	1	0	0	1	VT	VT	VT	VT
2	6	0	1	1	1	0	0	0	0	1	0	0	0	1	0	0	1	0	0	0	1	SO	SO	SO	SO	
2	7	0	0	0	0	1	0	1	0	1	0	1	0	1	0	1	0	1	0	1	0	SP	SP	SP	SP	
2	8	1	0	0	1	0	0	0	0	0	0	0	0	0	0	0	0	0	0	0	0	HT	HT	HT	HT	
2	9	0	0	0	1	1	0	0	0	1	0	0	0	1	0	0	0	1	0	0	0	BS	BS	BS	BS	
2	10	1	0	0	1	1	1	0	1	0	1	0	1	1	0	0	1	1	0	0	1	1	0	1	1	
3	1	0	0	0	0	0	1	1	0	0	1	1	0	0	1	1	0	0	1	1	0	0	0	0	0	
3	2	0	1	0	1	1	0	0	0	0	0	0	0	0	0	0	0	0	0	0	0	LF	LF	LF	LF	
3	3	0	0	0	0	0	1	0	1	0	0	1	1	0	0	1	1	0	0	1	0	0	0	0	0	
3	4	1	1	1	1	1	1	1	1	1	1	1	1	1	1	1	1	1	1	1	1	DEL	DEL	DEL	DEL	
3	5	1	1	0	1	0	1	1	0	1	0	0	1	1	0	1	1	0	1	0	1	0	0	0	0	
3	6	0	1	1	1	1	0	1	0	0	1	0	0	0	1	0	0	0	1	0	0	0	0	0	0	
3	7	1	1	1	1	0	0	1	0	1	1	0	1	0	1	0	1	1	1	0	0	0	0	0	0	
3	8	0	0	0	0	0	1	0	1	0	1	0	1	0	1	0	1	1	0	0	1	P	P	DLE	DLE	
3	9	1	1	1	1	0	0	0	1	1	0	0	1	1	0	0	0	0	0	0	0	0	0	SI	SI	
3	10	0	1	0	1	1	1	1	0	0	1	0	0	1	1	0	0	0	1	0	1	0	0	0	0	

MATRIX ADDRESS		COMMON					UNSHIFT				SHIFT				CONTROL				SHIFT CONTROL				CHARACTER			
X	Y	B1	B2	B3	B4	B5	B6	B7	B8	B5	B6	B7	B8	B5	B6	B7	B8	B5	B6	B7	B8	US	S	C	SC	
4	1	1	0	0	1	0	1	1	0	0	0	1	0	1	1	1	0	0	1	0	1	0	1	0	0	
4	2	1	0	0	1	0	0	1	1	0	0	1	1	0	0	0	0	0	0	0	0	1	1	0	1	
4	3	1	1	1	1	1	0	0	1	1	1	0	1	0	0	0	0	1	0	0	1	0	1	0	0	
4	4	1	1	0	1	0	0	0	1	0	1	1	0	1	0	0	0	1	0	0	0	K	VT	ESC	0	
4	5	0	0	1	1	0	0	0	0	1	1	0	1	0	0	0	0	1	0	0	1	L	FF	FS	0	
4	6	0	0	1	1	0	0	0	1	0	1	0	0	0	1	0	0	1	1	0	0	0	0	0	0	
4	7	0	1	1	1	1	0	0	1	0	0	1	0	1	0	1	0	1	0	0	1	0	0	0	0	
4	8	0	0	1	1	0	0	0	1	1	0	0	1	1	0	0	0	0	0	0	0	L	FF	EF	0	
4	9	1	1	0	1	0	0	0	1	0	0	1	0	0	0	1	0	0	0	1	0	0	0	0	0	
4	10	0	0	0	1	0	1	1	0	0	1	0	0	1	1	0	1	0	1	0	0	R	0	0	0	
5	1	0	1	1	0	0	1	1	0	0	1	0	0	1	1	1	0	0	1	0	1	R	N	0	0	
5	2	1	0	1	0	0	1	0	1	0	1	0	1	0	0	1	1	0	0	1	U	U	NAK	NAK		
5	3	1	0	0	1	0	1	0	1	0	1	0	1	0	0	0	1	0	0	1	Y	Y	EM	EM		
5	4	0	1	0	1	0	0	0	1	1	0	0	1	0	0	0	0	0	0	0	J	J	LF	LF		
5	5	0	0	0	1	0	0	0	0	1	0	0	1	0	0	0	0	0	0	1	H	H	BS	BS		
5	6	1	0	1	1	0	0	0	1	0	1	1	0	0	0	1	1	0	0	0	M	J	CR	GS		
5	7	0	1	1	1	1	0	0	1	0	1	1	0	0	0	1	1	0	0	0	N	0	SO	RS		
5	8	1	0	1	1	0	0	0	0	1	0	0	0	0	0	1	0	0	0	1	M	M	CR	JR		
5	9	0	1	1	1	0	0	0	0	1	0	0	0	0	0	1	0	0	0	1	N	N	SO	SO		
5	10	1	1	1	0	0	1	1	0	0	1	0	0	1	1	0	1	1	0	0	2	0	0	0	0	
6	1	1	0	1	0	0	1	1	0	0	0	1	1	0	0	1	1	0	0	0	5	0	5	0	0	
6	2	0	1	0	0	0	1	0	1	1	1	0	1	1	1	0	0	0	1	0	0	R	R	DC2	DC2	
6	3	0	0	1	0	0	1	0	1	1	0	1	1	0	0	0	1	0	0	0	T	T	DC4	DC4		
6	4	0	1	1	0	0	0	0	1	1	0	0	1	1	0	0	0	0	0	0	F	F	ACK	ACK		
6	5	1	1	1	0	0	0	0	1	0	0	1	0	0	0	1	0	0	0	1	G	G	BEL	BEL		
6	6	0	1	1	0	0	1	0	1	0	1	0	1	0	0	0	1	0	0	0	V	V	SYN	SYN		
6	7	0	1	0	0	0	0	0	1	0	0	1	0	0	0	1	0	0	0	1	B	B	STX	STX		
6	8	0	0	0	1	0	0	0	1	0	0	0	1	0	0	0	1	0	0	0	CAN	CAN	CAN	CAN		
6	9	1	0	0	1	0	0	1	1	0	0	1	1	0	0	1	1	0	0	1	EM	EM	EM	EM		
6	10	0	0	1	0	0	1	1	0	1	0	0	0	1	1	0	1	0	0	0	4	S	4	S		

Negative True Logic
B1 - B7 - ASCII Code
B8 - Even parity (on B1, B2, B3, B4, B5, B6, B7, B8)
B9 - Selective Repeat Bit

Note: Use B9 if parity bit is desired.